

SCHEDA TECNICA TECHNICAL FEATURES

Art. T150

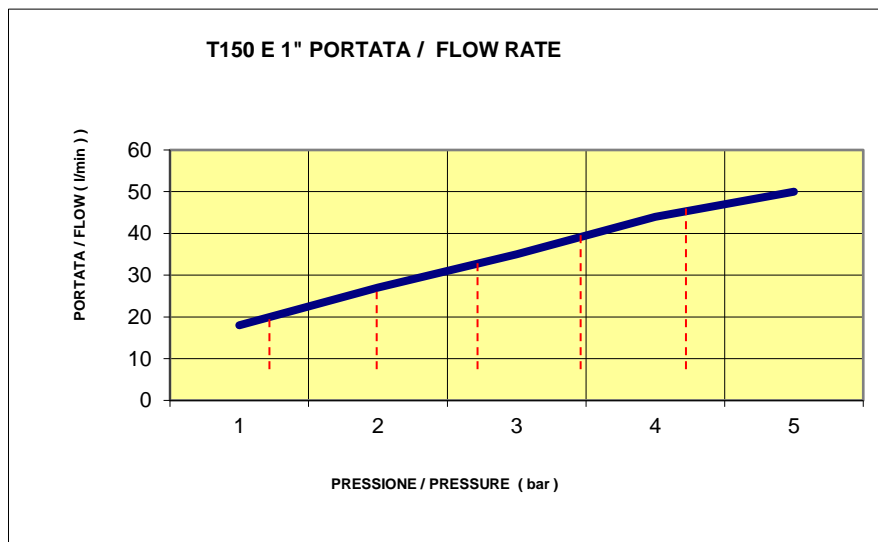
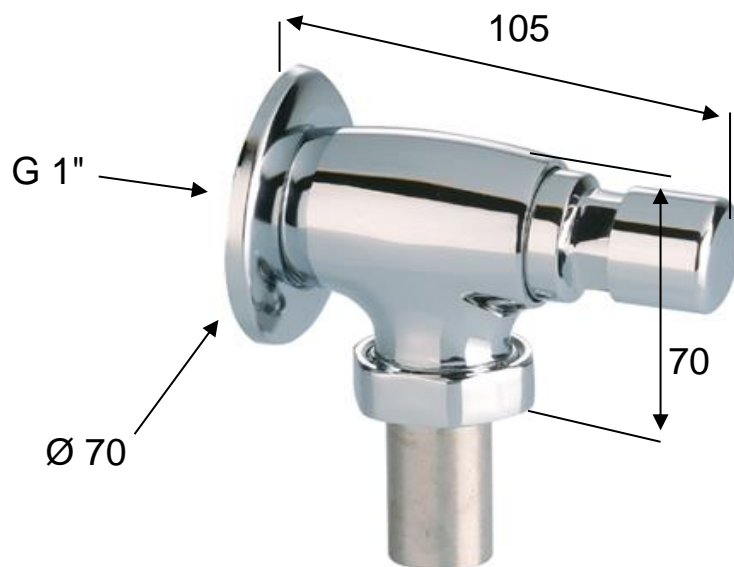

APERTURA / OPENING 5/6 s

MATERIALI / MATERIALS

OTTONE CROMATO / CHROME PLATING BRASS

CROMATURA / CHROME PLATING

UNI EN 248